



ALIARADAR

Non-Contacting Radar Level Transmitter

Model ARL5200 Series

GENERAL

ALIARADAR ARL5200 series non-contact radar level transmitter based on Frequency Modulated Continuous Wave (FMCW) technology and smart algorithms to maximize measurement accuracy, reliability and signal strength, and enables it to deliver superior measurement reliability with greater signal-to-noise ratio, even in small tanks and challenging fast-filling vessels. Non-contacting radar technology is ideal for a wide range of applications, and is unaffected by process conditions such as density, viscosity, temperature, pressure, Vapours, Conductivity, etc. Ideal for level measurement in complex applications such as liquids, slurries, solids, particles and dust.

FEATURES

- Unique FMCW radar technology for optimal performance
- High frequency 80 GHz fast-sweep for application flexibility
- Measuring range up to 150 m (492 ft), high accuracy of ± 2 mm
- Non-contact radar, free of wear and pollution
- Anti-interference of noise, vapor, dust, foam, vacuum, etc.
- Small beam angle & focus energy to enhance anti-interference ability
- The measurement of low permittivity constant media is more stable

STANDARD SPECIFICATION

- | | | | |
|------------------------|--|------------------------|--|
| ● Measure Principle | : Frequency Modulated Continuous Wave(FMCW) | ● Display | : 4-6 Digit LCD with Bargraph |
| ● Frequency Range | : 77-82 GHz | ● Keypad | : 4 internal keys for programming |
| ● Measure Range | : 0-150 m | ● Unit | : ft, in, m, cm, mm |
| ● Resolution | : 1 mm / 0.003 ft | ● Ambient Temperature | : -40~80 °C |
| ● Repeatability | : +/-0.5 mm | ● Process Temperature | : -40~260 °C (Max.) |
| ● Accuracy | : +/-2 mm... +/-5 mm | ● Process Pressure | : -1.0~25 bar G (Max.) |
| ● Blind Area | : 0.01 - 0.03 m | ● Humidity | : 0-100% RH, non-condensing |
| ● Beam Angle α | : 14° / 8° / 6° / 3° | ● Max. Cable Length | : 40 m (For single cavity housing) |
| ● Sensor Update Rate | : >1s (Dependent on configuration setting) | ● Power Supply | : 15-28 VDC (2-Wire) |
| ● Maximum Level Rate | : Max. 200 mm/s | | : 24 VDC \pm 10% (4-Wire) |
| ● Ambient Temp. Effect | : +/-1 mm (+/-0.04 in.) / 10 K | | : 90-253 VAC, 50 / 60 Hz (4-Wire) |
| ● Material | | ● Power Consumption | : 22.5 mA / 1W (Max.) (2-Wire) |
| Antenna | : PTFE / PEEK | ● Current Output | : 4-20 mA (2-Wire, 4-Wire) |
| Process Connection | : PTFE / S.S. 304 / S.S. 316 / S.S. 316L / S.S + PTFE | Load | : Rohm=(VDC-15) * 50 |
| Housing | : Aluminum Alloy (Standard) | Resolution | : 1.6 μ A |
| | : S.S. 304 (Option) | ● Damping | : 0-999 s |
| O-ring | : FKM | ● Communication | : HART signal (Compatible) |
| ● Process Connection | : Thread (3/4" NPT, G3/4", 1-1/2" NPT, G1-1/2", G3", 3" NPT) | | : RS485 (MODBUS Protocol) |
| | : Flange (DN50-DN200) | ● Data Storage | : Operation parameters and totalization date are stored by EEPROM for more than 10 years |
| | : Universal Flange (DN100-DN200) | ● EMI / RFI Effect | : Follow SAMA PMC 33.1 from 20 to 1000 MHz and for field strengths up to 30 V/m |
| ● Protection Class | : IP67 | ● Vibration Resistance | : 2g at 10-1000 Hz according to IEC 61298-3 |
| | : Explosion Proof, Ex d IIC T6 | ● Cable Entry | : Standard: M20, Option: 1/2" NPTF |
| | : Intrinsically Safe, Ex ia IIC T6 | | |



ALIA TECHNOLOGY LLC

633 W. 5th Street, 26th Floor, Los Angeles, CA 90071, USA
 TEL : + 1- 213 - 533 - 4139 FAX : + 1 - 213 - 223 - 2317



URL : www.alia-inc.com
 E-mail : alia@alia-inc.com
 ARL5200V1.2.3.r1.A4.en



WIRING DIAGRAM

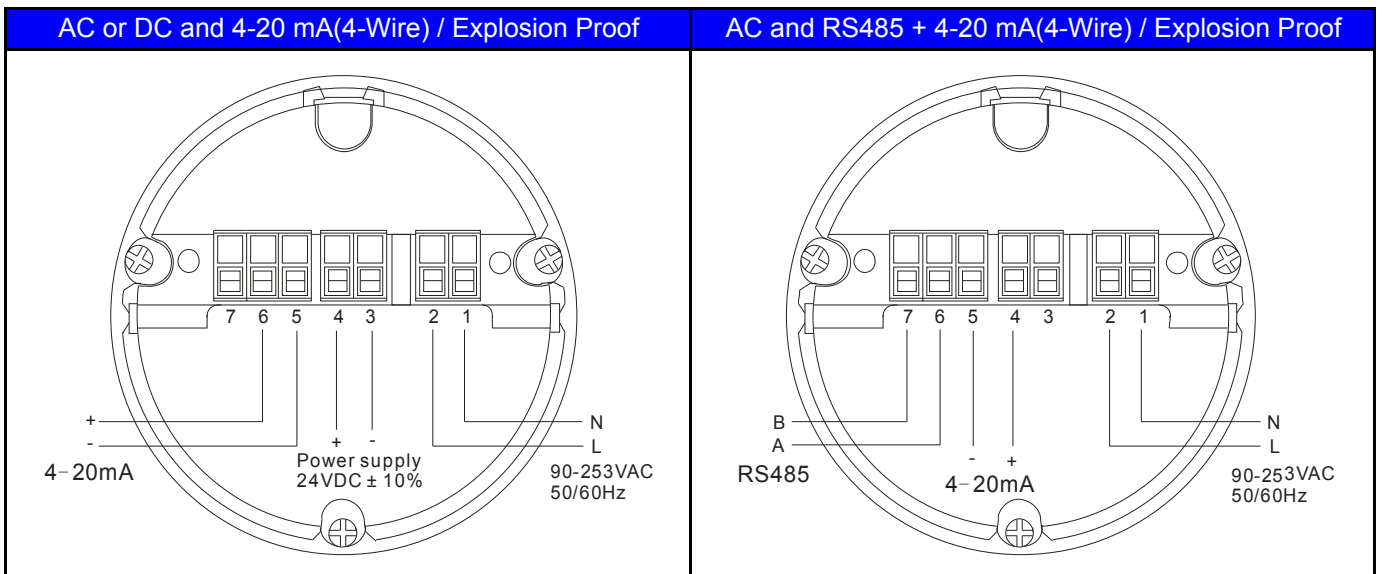
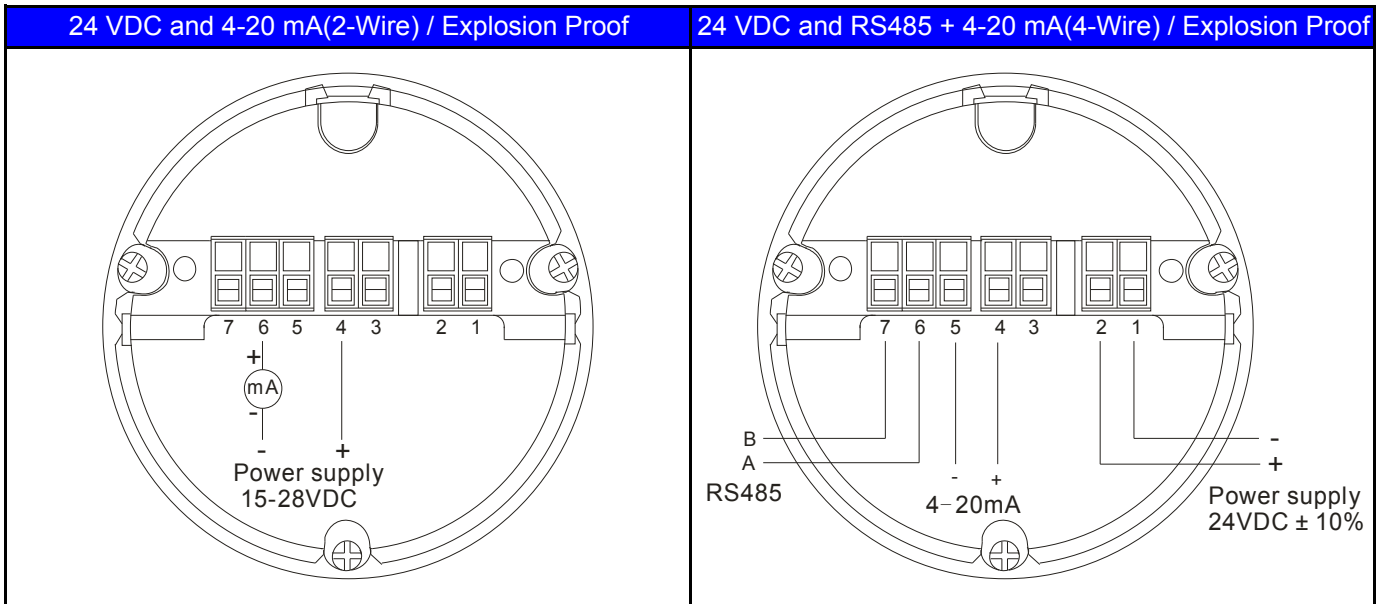
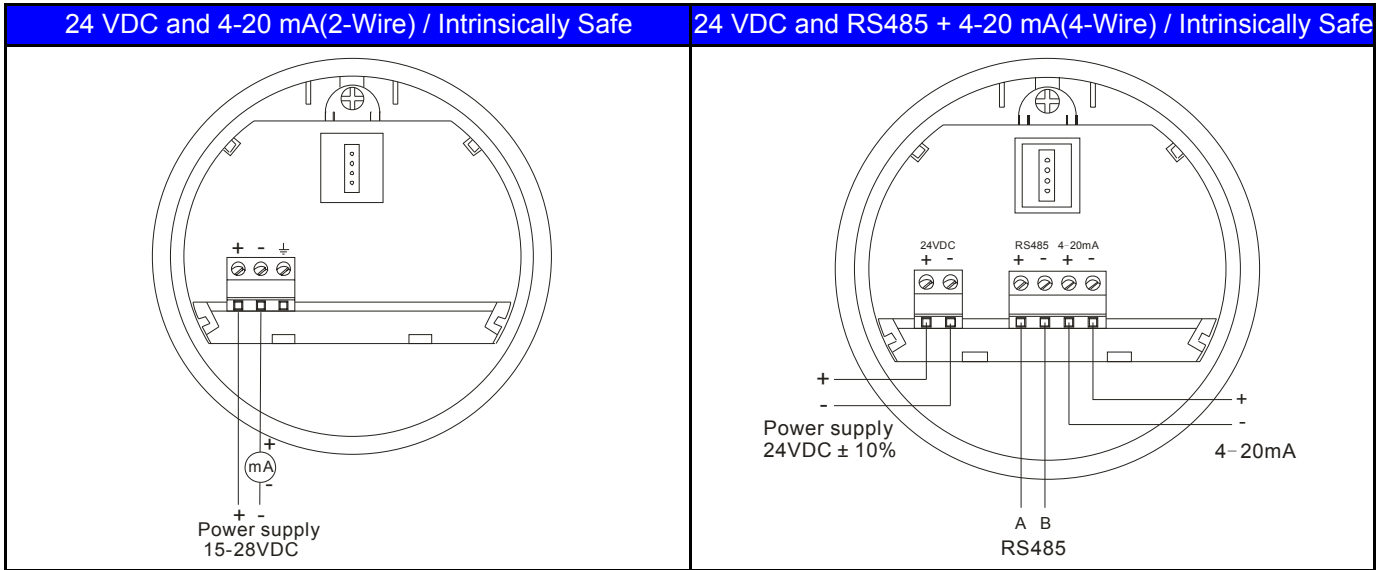

➤ DIMENSIONS

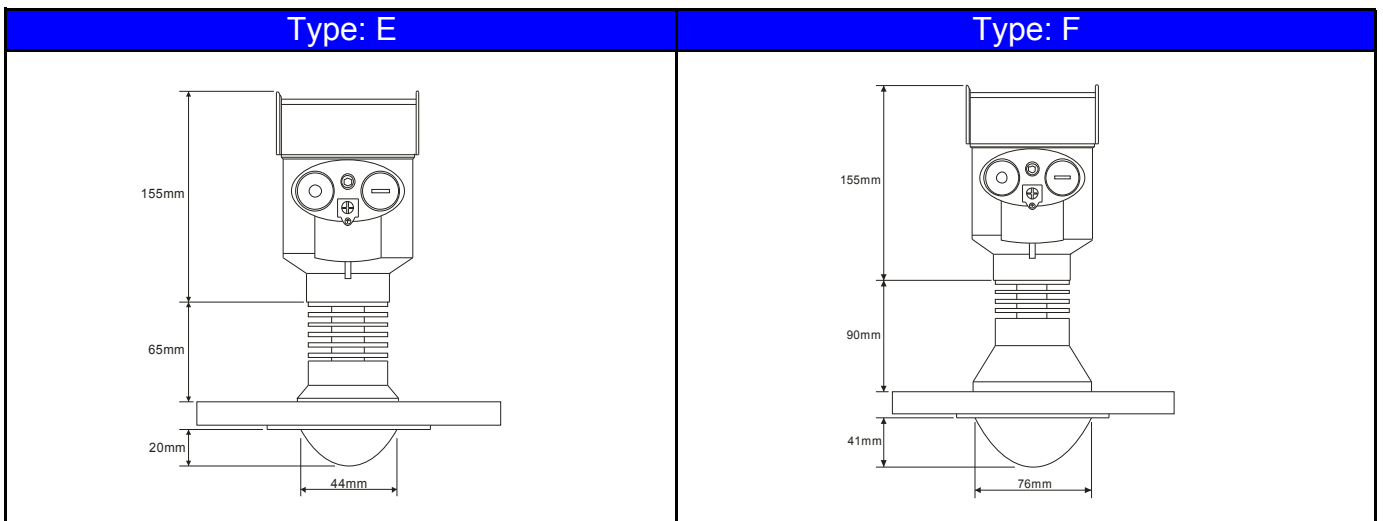
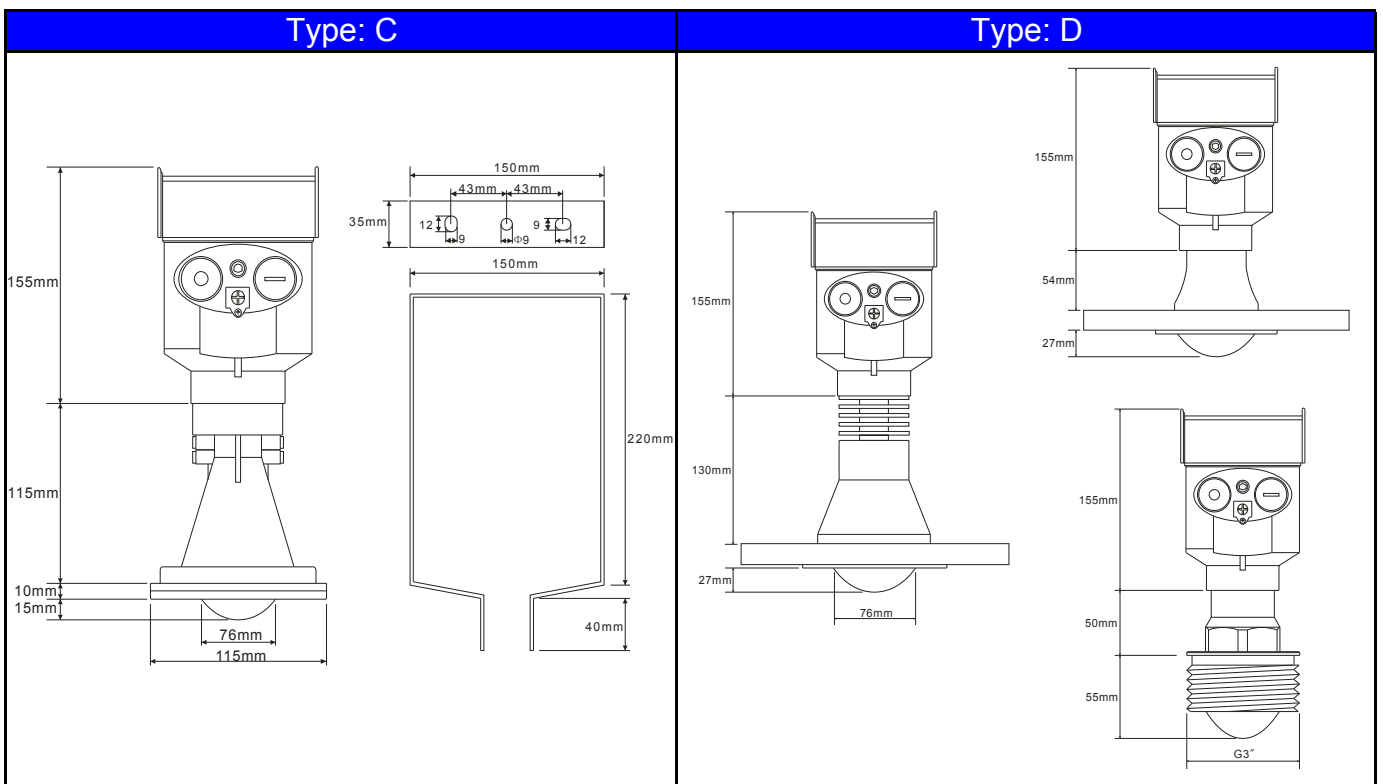
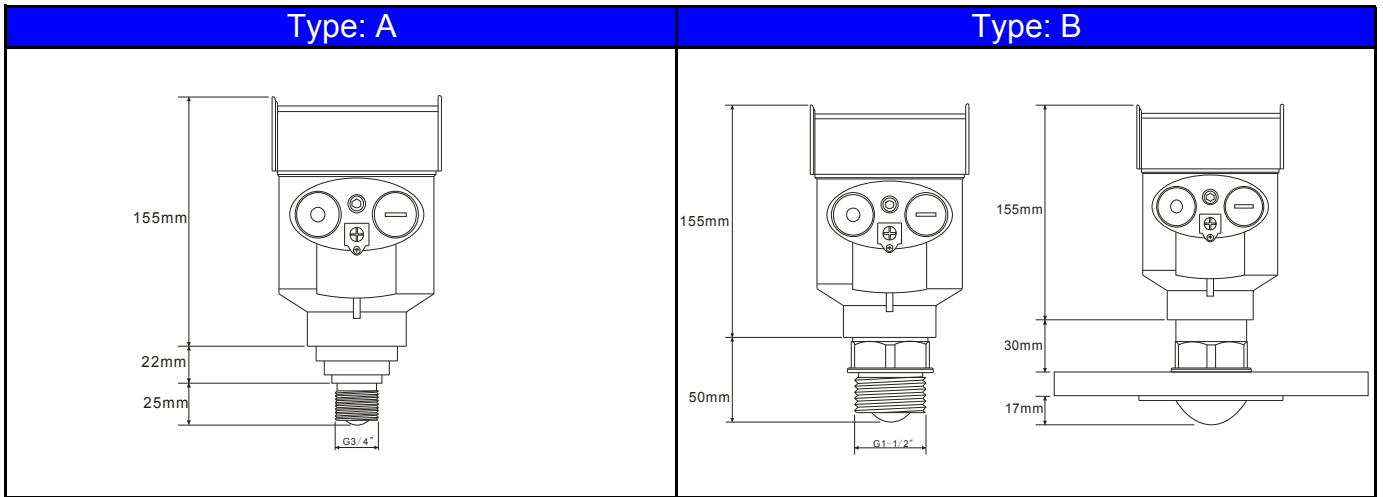

➤ DIMENSIONS & DISPLAY

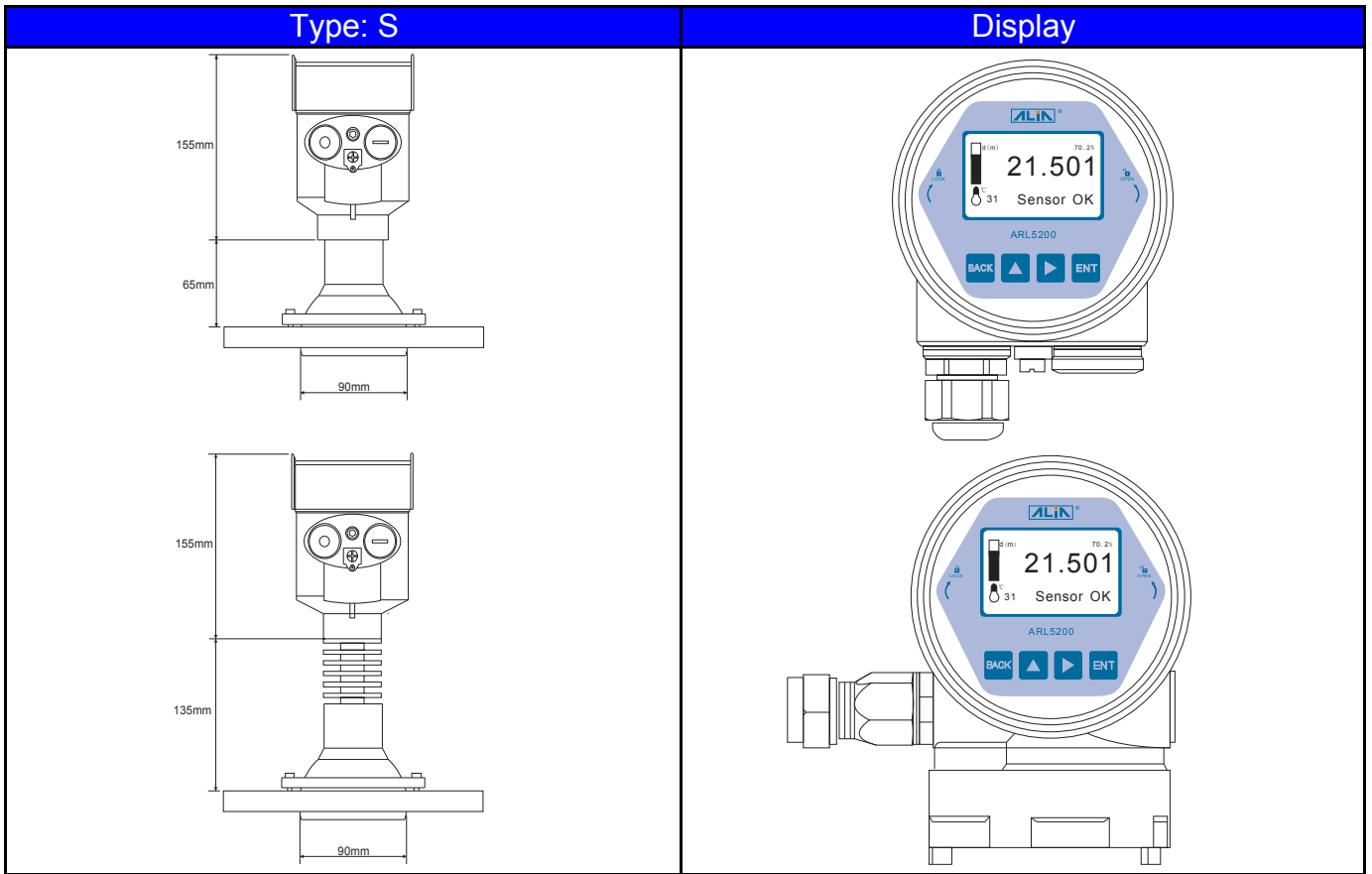

➤ BEAM ANGLE

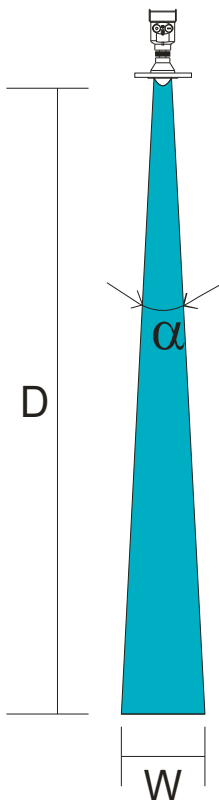

Antenna Size	φ 21 mm	φ 32 mm	φ 44 mm	φ 76 mm
Beam Angle α	14°	8°	6°	3°

Distance D	Beam Angle Diameter (W)			
5 m	1.23 m	0.70 m	0.53 m	0.27 m
10 m	2.46 m	1.40 m	1.05 m	0.53 m
20 m		2.80 m	2.10 m	1.05 m
30 m		4.20 m	3.15 m	1.58 m
40 m				2.10 m
50 m				2.62 m
60 m				3.15 m
70 m				3.67 m
80 m				4.19 m
90 m				4.72 m
100 m				5.24 m
110 m				5.77 m
120 m				6.29 m
130 m				6.81 m
140 m				7.34 m
150 m				7.86 m

MODEL & SPECIFICATION

Type: ARL5200-A Application: A little vapor, no crystallization, no corrosion



ARL5200-A Series					
Example: ARL5200-A1-G1NN					
ARL5200-A	X	-XX	X	X	Description
Type	1				Range: 0-10 m Accuracy: +/-2 mm
Flange Size	-G1				Thread: G3/4" _ Beam Angle α : 14° _ Antenna Size: ϕ 21
	-P1				Thread: 3/4" NPT _ Beam Angle α : 14° _ Antenna Size: ϕ 21
	-G2				Thread: G1" _ Beam Angle α : 14° _ Antenna Size: ϕ 21
	-P2				Thread: 1" NPT _ Beam Angle α : 14° _ Antenna Size: ϕ 21
	-02				2" (DN50) _ Beam Angle α : 14° _ Antenna Size: ϕ 21
	-03				3" (DN80) _ Beam Angle α : 14° _ Antenna Size: ϕ 21
Material			N	Thread Material: S.S. 316L, Antenna Material: PTFE	
			Q	Flange Material: S.S. 304, Antenna Material: PTFE	
			R	Flange Material: S.S. 316, Antenna Material: PTFE	
Max. temperature / Pressure			N	Temp. : -40~100 °C, Pressure: -1.0~16 bar *Note	
Please turn to option of Process Connection And Transmitter for model selection					

Note: The maximum pressure is also related to flange specifications.

Type: ARL5200-B Application: A little vapor condensations and corrosion



ARL5200-B Series					
Example: ARL5200-B1-3SH					
ARL5200-B	X	-X	X	X	Description
Type	1				Range: 0-30 m Accuracy: +/-2 mm
Flange Size	-G				Thread: G1-1/2" _ Beam Angle α : 8° _ Antenna Size: ϕ 32
	-P				Thread: 1-1/2" NPT _ Beam Angle α : 8° _ Antenna Size: ϕ 32
	-2				2" (DN50) _ Beam Angle α : 8° _ Antenna Size: ϕ 32
	-3				3" (DN80) _ Beam Angle α : 8° _ Antenna Size: ϕ 32
	-4				4" (DN100) _ Beam Angle α : 8° _ Antenna Size: ϕ 32
Material			N	Thread Material: PTFE, Antenna Material: PTFE	
			4	Thread Material: S.S. 304, Antenna Material: PTFE	
			L	Thread Material: S.S. 316L, Antenna Material: PTFE	
			P	Flange Material: PTFE, Antenna Material: PTFE	
			Q	Flange Material: S.S. 304+PTFE, Antenna Material: PTFE	
			R	Flange Material: S.S. 316+PTFE, Antenna Material: PTFE	
Max. temperature / Pressure			N	Temp. : -40~80 °C, Pressure: -1.0~3.0 bar (Material: N / P)	
			H	T. : -40~120 °C, P. : -1.0~25 bar (Material: 4 / L / Q / R / S) *Note	
Please turn to option of Process Connection And Transmitter for model selection					

Note: The maximum pressure is also related to flange specifications.

MODEL & SPECIFICATION

Type: ARL5200-C Application: River, shoal or mudslide



ARL5200-C Series					
Example: ARL5200-C1-NNN					
ARL5200-C	X	-X	X	X	Description
Type	1				Range: 0-30 m Accuracy: +/-2 mm
	2				Range: 0-150 m Accuracy: +/-5 mm
Flange Size	-N				With mounting bracket _ Beam Angle α : 3° _ Antenna Size: ϕ 76
	-3				3" (DN80) _ Beam Angle α : 3° _ Antenna Size: ϕ 76
	-4				4" (DN100) _ Beam Angle α : 3° _ Antenna Size: ϕ 76
	-5				5" (DN125) _ Beam Angle α : 3° _ Antenna Size: ϕ 76
	-6				6" (DN150) _ Beam Angle α : 3° _ Antenna Size: ϕ 76
Material			N	Mounting bracket: S.S. 304, Antenna Material: PTFE	
			P	Flange Material: PP(Thickness:20mm), Antenna Material: PTFE	
Max. temperature / Pressure			N	Temp. : -40~80 °C, Pressure: -1.0~3.0 bar	
Please turn to option of Process Connection And Transmitter for model selection					

Type: ARL5200-D Application: Storage tank and reaction tank



ARL5200-D Series					
Example: ARL5200-D1-3TH					
ARL5200-D	X	-X	X	X	Description
Type	1				Range: 0-30 m Accuracy: +/-2 mm
	2				Range: 0-150 m Accuracy: +/-5 mm
Flange Size	-G				Thread: G3" _ Beam Angle α : 3° _ Antenna Size: ϕ 76
	-P				Thread: 3" NPT _ Beam Angle α : 3° _ Antenna Size: ϕ 76
	-3				3" (DN80) _ Beam Angle α : 3° _ Antenna Size: ϕ 76
	-4				4" (DN100) _ Beam Angle α : 3° _ Antenna Size: ϕ 76
	-5				5" (DN125) _ Beam Angle α : 3° _ Antenna Size: ϕ 76
	-6				6" (DN150) _ Beam Angle α : 3° _ Antenna Size: ϕ 76
Material			4	Thread Material: S.S. 304, Antenna Material: PTFE	
			L	Thread Material: S.S. 316L, Antenna Material: PTFE	
			Q	Flange Material: S.S. 304+PTFE, Antenna Material: PTFE	
			R	Flange Material: S.S. 316+PTFE, Antenna Material: PTFE	
			S	Flange Material: S.S. 316L+PTFE, Antenna Material: PTFE	
			T	Flange Material: S.S. 304+PEEK, Antenna Material: PEEK	
			W	Flange Material: S.S. 316L+PEEK, Antenna Material: PEEK	
Max. temperature / Pressure			N	T. : -40~150 °C, P: -1.0~6 bar (Material: 4 / L / Q / R / S)	
			H	T. : -40~260 °C, P. : -1.0~25 bar (Material: T / W) *Note	
Please turn to option of Process Connection And Transmitter for model selection					

Note : The maximum pressure is also related to flange specifications.

MODEL & SPECIFICATION

Type: ARL5200-E Application: Reaction tank, high pressure or corrosion



ARL5200-E Series					
Example: ARL5200-E1-4RN					
ARL5200-E	X	-X	X	X	Description
Type	1				Range: 0-30 m Accuracy : +/-2 mm
Flange Size		-2			2" (DN50) _ Beam Angle α : 6° _ Antenna Size: ϕ 44
		-3			3" (DN80) _ Beam Angle α : 6° _ Antenna Size: ϕ 44
		-4			4" (DN100) _ Beam Angle α : 6° _ Antenna Size: ϕ 44
		-5			5" (DN125) _ Beam Angle α : 6° _ Antenna Size: ϕ 44
		-6			6" (DN150) _ Beam Angle α : 6° _ Antenna Size: ϕ 44
Material			Q		Flange Material: S.S. 304+PTFE, Antenna Material: PTFE
			R		Flange Material: S.S. 316+PTFE, Antenna Material: PTFE
			S		Flange Material: S.S. 316L+PTFE, Antenna Material: PTFE
Max. temperature / Pressure				N	Temp. : -40~200 °C, Pressure: -1.0~25 bar *Note
Please turn to option of Process Connection And Transmitter for model selection					

Note: The maximum pressure is also related to flange specifications.

Type: ARL5200-F Application: Reaction tank, high pressure, corrosion, with a little condensation or crystallization



ARL5200-F Series					
Example: ARL5200-F1-4RN					
ARL5200-F	X	-X	X	X	Description
Type	1				Range: 0-30 m Accuracy: +/-2 mm
	2				Range: 0-150 m Accuracy: +/-5 mm
Flange Size		-3			3" (DN80) _ Beam Angle α : 3° _ Antenna Size: ϕ 76
		-4			4" (DN100) _ Beam Angle α : 3° _ Antenna Size: ϕ 76
		-5			5" (DN125) _ Beam Angle α : 3° _ Antenna Size: ϕ 76
		-6			6" (DN150) _ Beam Angle α : 3° _ Antenna Size: ϕ 76
Material			Q		Flange Material: S.S. 304+PTFE, Antenna Material: PTFE
			R		Flange Material: S.S. 316+PTFE, Antenna Material: PTFE
			S		Flange Material: S.S. 316L+PTFE, Antenna Material: PTFE
Max. temperature / Pressure				N	Temp. : -40~200 °C, Pressure: -1.0~25 bar *Note
Please turn to option of Process Connection And Transmitter for model selection					

Note: The maximum pressure is also related to flange specifications.

MODEL & SPECIFICATION

Type: ARL5200-S Application: Solid particles, powders, lump material



ARL5200-S Series						
Example: ARL5200-S1-44-UF-MM						
ARL5200-S	X	-X	X	-XX	-XX	Description
Type	1					Range: 0-30 m, Accuracy: +/-5 mm
	2					Range: 0-150 m, Accuracy: +/-5 mm
Flange Size	-4					4" (DN100) _ Beam Angle α : 3° _ Antenna Size: ϕ 76
	-5					5" (DN125) _ Beam Angle α : 3° _ Antenna Size: ϕ 76
	-6					6" (DN150) _ Beam Angle α : 3° _ Antenna Size: ϕ 76
	-8					8" (DN200) _ Beam Angle α : 3° _ Antenna Size: ϕ 76
Material	4					Flange Mat.: S.S. 304, Antenna Mat.: PTFE *Note
	P					Flange Mat.: PP, Antenna Mat.: PTFE *Note
Flange Type and Other				-UF	Universal Flange, With purge device	
Max. temperature / Pressure				-NN	Temp. : -40~80 °C, P. : 0 bar (Flange Mat. : PP)	
				-MM	Temp. : -40~110 °C, P. : 0 bar (Flange Mat. : S.S. 304)	
				-HH	Temp. : -40~200 °C, P. : 0 bar (Flange Mat. : S.S. 304)	
Please turn to option of Process Connection And Transmitter for model selection						

Note: Flange material S.S. 304 with a thickness of 12 mm. Flange material PP with a thickness of 20 mm

Process Connection And Transmitter

Example: -2NN-ANN-NN						
	-X	XX	-X	XX-	XX	Description
Process Connection	-N					Thread or With mounting bracket
	-1					PN10
	-2					PN16
	-3					PN25
	-4					PN40
	-A					ANSI 150#
	-B					ANSI 300#
	-J					JIS 10K
	-K					JIS 20K
Flange thickness	NN					Thread / Mounting bracket / 12 mm Flange Thickness (P. \leq 3 bar)
	P2					20 mm / Flange material: PP (P. \leq 3 bar)
	M2					20 mm / Flange material: Stainless Steel (P. \leq 25 bar)
	ST					International standard Flange / Thread (Material: Stainless Steel)
Power Supply / Output	-A					15-28 VDC / 4-20 mA (2-Wire) with HART
	-B					24 VDC \pm 10% / RS485 / 4-20 mA (4-Wire)
	-C					90-253 VAC or 24 VDC \pm 10% / 4-20 mA (4-Wire) with HART
	-D					90-253 VAC / RS485 / 4-20 mA (4-Wire)
Protection Class	NN-					IP67
	IT-					Intrinsically Safe, Ex ia IIC T6 (Used only in Power supply / Output: A / B)
	EX-					Explosion Proof, Ex d IIC T6 (Used only in the double cavity housing)
Option	NN					None
	PT					Cable Entry: 1/2" NPTF
	HS					Housing Material S.S. 304
	01-40					The remote converter, Cable Length 01-40 m